

**Manufacturer's Installation Standard
For
Lightning Protection Systems Using
Early Streamer Emission Air Terminals**

HBP-21

CONTENTS

Introduction		Page
1.	Scope	3
2.	Glossary	4
3.	General Requirements	6
Level 1	Installation Standard for Early Streamer Emission	
	Lightning Protection Systems	
4.	Level 1 General Installation and Component Requirements	10
5.	Level 1 Air Terminal Installation Requirements	12
6.	Level 1 Bonding Requirements	15
7.	Level 1 Grounding System Requirements	16
8.	Level 1 Structural Steel Systems	20
Level 2	Installation Standard for Early Streamer Emission	
	Lightning Protection Systems	
9.	Level 2 General Installation and Component Requirements	23
10.	Level 2 Air Terminal Installation Requirements	25
11.	Level 2 Bonding Requirements	29
12.	Level 2 Grounding System Requirements	29
13.	Level 2 Structural Steel Systems	32
Level 3	Installation Standard for Early Streamer Emission	
	Lightning Protection Systems	
14.	Level 3 General Installation and Component Requirements	34
15.	Level 3 Components	36
16.	Level 3 Air Terminal Installation Requirements	37
17.	Level 3 Grounding System Requirements	39
18.	Level 3 Structural Steel Systems	42

INTRODUCTION

1. Scope

- 1.1 The requirements of this standard cover the design of systems using Early Streamer Emission (“ESE”) air terminals for strikes. The Standard is divided into Three Levels of Protection. Electrical transmission lines and equipment are not within the scope of this standard.
- 1.2 These requirements apply to lightning protection systems that are complete and cover all parts of a structure. Partial systems are not covered by this standard.
- 1.3 Where fittings, devices or other components required by this standard are available as listed or labeled, such components shall be used. Otherwise the components shall be approved by the authority having jurisdiction (i.e. Engineer of Record, Architect, Owner, Applied Research Laboratories or Underwriter’s Laboratories).
- 1.4 This Manufacturer’s standard is based upon Heary Bros.’ 30 years experience in designing lightning protection systems. Because of the lack of a complete understanding of the interaction between lightning and ground based objects and the lightning attachment process, the number and placement of air terminals set forth in this Manufacturer’s Standard is based solely on Heary Bros.’ experience and its air terminals and the configuration of those terminals have not been scientifically proven or guaranteed to have a measurable zone of protection, NFPA 780, states that the NFPA “does not independently test, evaluate or verify the accuracy of any information or the soundness of any judgments contained in its codes and standards.”

2. Glossary

2.1 For the purpose of this standard the following definitions apply:

Lightning Protection System is complete system of air terminals(s), conductors, ground terminals, bonding conductors, transient voltage surge suppression devices and other components required to complete a system.

2.2 AIR TERMINAL:

Is the component of the system that is intended to intercept the lightning strokes.

2.3 APPROVED:

Acceptable to the “authority having jurisdiction”.

2.4 AUTHORITY HAVING JURISDICTION:

Is the organization, office or individual responsible for “approving” the equipment, and installation or a procedure.

2.5 BONDING:

An electrical connection between an electrically conductive object and a component of a lightning protection system that is intended to significantly reduce potential differences created by lightning currents.

2.6 CABLE:

A conductor formed of a number of wires stranded together.

2.7 CHIMNEY:

A smoke or vent stack having a flue with cross sectional area less than 500 sq in (.3 sq m) and a total height of less than 75 feet (23m).

2.8 CONDUCTOR:

The portion of a lightning protection system that is intended to carry the lightning discharge to the ground.

2.8.1 MAIN CONDUCTOR:

A conductor that interconnects air terminals and serves as a down lead to ground.

2.8.2 BONDING CONDUCTOR:

A conductor intended to be used for potential equalization between metal bodies and the lightning protection system. Bonding conductors are not designed or intended to carry main lightning current.

2.9 FASTENER:

An attachment to secure the conductor to the structure.

2.10 GROUNDED:

Connected to earth or to some conducting body that is connected to earth.

2.10.1 GROUND GRID:

A system of grounding electrodes consisting of interconnected bare cables buried in the earth.

2.10.2 GROUND TERMINAL (ELECTRODE):

The portion of a lightning protection system that is installed for the purpose of providing electrical contact with earth.

2.11 LIGHTNING STRIKE:

The entire lightning event that can consist of one or more lightning strokes.

2.12 LOOP CONDUCTOR:

A conductor that encircles a structure that is used to interconnect ground terminals, main conductors or other grounded bodies.

2.13 METAL FRAME STRUCTURE:

A structure with electrically continuous structure members of sufficient size to provide electrical path equivalent to that of the lightning conductors in this standard.

2.14 SHALL:

Indicates a mandatory requirement of this Standard.

2.15 SHOULD:

Indicates a recommendation or that which is advised but not required.

2.16 SURGE ARRESTORS:

Are devices designed to limit damaging surge voltages by discharging or bypassing the current while maintaining the ability of repeating these functions. Heary Brothers Lightning Protection Co., Inc. and its Division Lightning Preventor of America do not manufacture Surge Arrestors nor do they warranty the equipment.

3. GENERAL REQUIREMENTS

3.1 GENERAL DESIGN REQUIREMENTS:

A lightning protection system using an Early Streamer Emission Air Terminal (s) shall be designed with provisions for inspection and maintenance.

- 3.2 Every installation shall be reviewed by a prior study to determine the level of protection required (See Figure 3.5.1).
- 3.3 The position of the E.S.E. air terminal, including height of above structure shall be determined in accordance with the level of protection required. (See Figure 3.5.1)
- 3.4 The number of terminals will depend on the system design under the Manufacturer's Standard based upon the dimensions of the area to be protected. (See Figure 3.5.1)
- 3.5 There are multiple styles of E.S.E. air terminals and systems available. For purposes of this standard they have been divided into separate levels of protection, with each level having its own installation requirements. A chart is provided (See Figure 3.5.1) as a general guideline in determining which level of protection best fits the requirements of the project.
- 3.6 All bolts on bolt pressure connectors require to be torqued at 150 pound-inches (17N-m).
- 3.7 This Manufacturer's standard is based upon Heary Bros.' 30 years experience in designing lightning protection systems. Because of the lack of a complete understanding of the interaction between lightning and ground based objects and the lightning attachment process, the number and placement of air terminals set forth in this Manufacturer's Standard is based solely on Heary Bros.' experience and its air terminals and the configuration of those terminals have not been scientifically proven or guaranteed to have a measurable zone of protection, NFPA 780, states that the NFPA "does not independently test, evaluate or verify the accuracy of any information or the soundness of any judgments contained in its codes and standards."

Figure 3.5.1

Levels of Protection for ESE Lightning Protection Systems

FEATURES	LEVEL 1	LEVEL 2	LEVEL 3
Number of ESE Terminals Required Pursuant to System Design	1 Air Terminal (See Note: A)	1 Air Terminal (See Note: A)	1 Air Terminal (See Note: B)
Grounding Resistance Requirements	10Ω (ohms) or less	10 Ω (ohms) or less	25Ω (ohms) or less
Warranty	15 year material workmanship	15 year material workmanship	5 year material workmanship
Air Terminal height above all roof top projections	20' (6.1m)	20' (6.1 m)	7' (2 m)
Transient Voltage Surge Suppression	Shall be installed on all service entrances of electric, telephone, cable, and antenna lead-in.	Shall be installed on all service entrances of electric, telephone, cable, antenna lead-in.	Shall be installed on all service entrances of electric, telephone, cable, antenna lead-in.
ARL Listing and UL Listing mark on applicable components	Required	Required	Required
Building Height	Unlimited	Unlimited	Under 75' (23m)
Building Types	All	All	Residential, Farm, Agricultural, Small commercial.

(Note: A)

Manufacturer's Installation Standard HBP-21 Level 1 and Level 2 require one (1) ESE Air Terminal to be installed on the roof for every circular area of 337,810 feet. Structures may be on any height and the ESE lightning protection system must comply with all other requirements within this Manufacturer's Installation Standard HBP-21. This Manufacturer's standard is based upon Heary Bros.' 30 years experience in designing lightning protection systems. Because of the lack of a complete understanding of the interaction between lightning and ground based objects and the lightning attachment process, the number and placement of air terminals set forth in this Manufacturer's standard is based solely on Heary Bros.' experience and its air terminals and the configuration of those terminals have not been scientifically proven or guaranteed to have a measurable zone of protection. Consumers should be aware that the NFPA, in issuing its standard for lightning protection NFPA 780, states that the NFPA, "does not independently test, evaluate or verify the accuracy of any information or the soundness of any judgment contained in its codes and standards."

(Note: B)

Manufacturer's Installation Standard HBP-21 Level 3 requires one (1) ESE Air Terminal to be installed on the roof for every circular area of 70,650 feet. Structures may be of any height and the ESE lightning protection system must comply with all other requirements within this Manufacturer's Installation Standard HBP-21. The recommended number and placement of air terminals is based solely on Heary Bros.' 30 years of experience and its air terminals and the configuration of those terminals have not been scientifically proven or guaranteed to have a measurable zone of protection. Consumers should be aware that the NFPA, in issuing its standard for lightning protection, NFPA 780, states that the NFPA, "does not independently test, evaluate or verify the accuracy of any information or the soundness of any judgment contained in its codes and standards."

LEVEL 1

MANUFACTURER'S INSTALLATION
STANDARD

FOR

EARLY STREAMER EMISSION
LIGHTNING PROTECTION SYSTEMS

4. Level 1 General Installation and Component Requirements

- 4.1 An ESE lightning protection system installation consists of the following interconnected parts
- (a) One or more ESE air terminals
 - (b) Mast and mounting systems - as required based on level of protection desired.
 - (c) Bonding conductors - as required based on level of protection.
 - (d) Ground system – Single grid to loop conductor system.
 - (e) Equipotential Bonding.
 - (f) Transient Voltage Surge Suppression.

4.1.1 The number of ESE air terminals will depend on the system design under the Manufacturer’s Standard based upon the area indicated in Figure 3.5.1 for Level 1 type systems. The recommended number and placement of air terminals is based solely on Heary Bros.’ 30 years of experience and its air terminals and the configuration of those terminals have not been scientifically proven or guaranteed to have a measurable zone of protection. Consumers should be aware that the NFPA, in issuing its standard for lightning protection, NFPA 780, states that the NFPA, “does not independently test, evaluate or verify the accuracy of any information or the soundness of any judgment contained in its codes and standards.”

4.1.2 Components Tables 4.1.1.1 and Figure 4.1.1.2 provides minimum sizes and weights for use in ESE lightning protection system installation.

Figure 4.1.1.1

Type of conductor	Minimum Diameter	Copper Standard/ Metric	Aluminum Standard/ Metric
ESE Air Terminal	½” /12.7mm	½”/ 12.7 mm	½”/ 12.7 mm
Main Conductor Cable	Min Size each strand Weight Per Length Cross Sectional area	14AWG 375lbs /1000/ or 558 g/m 115,000 CM / 58 mm ²	13AWG 190lbs/1000/ 283 g/m 192000 CM/ 97 mm ²
Ground Terminals	Ground Rod / Ground Plate	¼” x 10’ (20mm x 3000mm)/ 24” x 24” x 20 gauge (600mm x 600mm) pure Copper plate minimum of 2 contact points each 8 sq inch contact to plate	NA

Figure 4.1.1.2

Early Streamer Emission Air Terminal

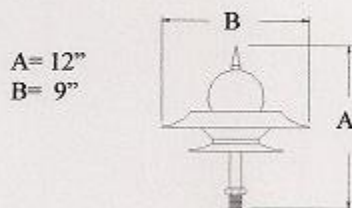

- 4.2 ESE Air terminals shall be sufficiently rigid to withstand mechanical damage. They shall be constructed of copper, copper alloy, aluminum or stainless steel. The main conductive parts of the ESE air terminal shall have the minimum dimensions in accordance with table 4.1.1.1 and Figure 4.1.1.2 for minimum dimensions of ESE Air Terminal.
- 4.2.1 Installation: Air terminals and their supports shall be mounted in such a way as to withstand the lightning currents, electromotive force, corrosion and effects of weather, heat, humidity, snow and wind.
NOTE: Wind design requirements should be consistent with local building code requirements.
- 4.2.2 Where an air terminal or mast is supported by conductive guys, the guys shall be connected from their points of anchorage to the closest down conductor(s) by a conductor equivalent in size to that of the down conductor(s).
- 4.2.3 The tip of any ESE air terminal or mast shall not be less than 20' (6.1m) above the protected structures, including antennas, cooling towers, tanks, roofs and masts.
- 4.2.4 The ESE air terminal shall be mounted on structures such as flagpoles, the top of pylons, light standards or on dedicated supports for structures at certain facilities, such as, sports facilities and stadiums, golf courses, public parks, camping sites and racetracks. The ESE unit shall be mounted at an elevation indicated in Section 4.2.3.
- 4.3 Storage areas for Flammable and Combustible Liquids or Flammable Gases. Structures containing these materials shall be grounded, but grounding alone does not constitute sufficient protection against atmospheric discharges.
- 4.4 Surge Suppression devices shall be installed on electric and telephone service entrances, antenna lead-ins, and electrical and electronic cables/ conductors entering or exiting the building.
- 4.4.1 Electrical Surge Suppression device shall be internally redundant and modular, in both surge suppression elements and fusing in construction for ease of field reparability. Manufacturers shall warranty the modules and fuse for the lifetime of the unit, with a minimum 10-year full unit warranty. Units shall be mounted as to minimize inductance installation. (i.e. As close to equipment to be protected or by use of documented low inductance cabling).
- 4.5 General, In determining the necessity of bonding a metal body to a lightning protection system, the following factors shall be considered:
- A. Bonding is required only if there is a likely to be a side flash between the lightning protection system and other grounded medium.
 - B. The influence of a non-grounded metal body, such as metal window frame in a non-conductive medium, is limited to its effectiveness as a short circuit conductor if a side flash occurs therefore, does not necessarily require bonding to the lightning protection system.
 - C. Bonding distance requirements depend on the technical evaluation of the number of down conductors and their location, the interconnection of other grounded systems, the proximity of grounded metal bodies to the down conductors and the flashover medium (Air or solid materials).
 - D. Metal bodies located in a steel frame structure shall be permitted to be inherently bonded through construction and further bonding shall not be required.
 - E. Metal antenna masts or supports located on a protected structure shall be bonded to the lightning protection system using main size conductors and listed fittings. The height of the air terminal shall maintain the minimum protection above these objects as specified in Section 4.2.3
NOTE: For additional bonding requirements see Section 5.2 and 5.3.
- 4.6 Components
- 4.6.1 A lightning protection system shall be made of components that are resistant to corrosion or shall be acceptably protected against corrosion. The following materials are acceptable:
- A. Copper of the grade required for commercial electrical work. Or a copper alloy with similar characteristics. Usually of 98 percent conductivity when annealed.
 - B. Aluminum conductors as acceptable as electrical grade aluminum.
- 4.6.2 Components shall be protected against deterioration due to local conditions. Any part of a copper system that is exposed to direct action of chimney gasses or other similar corrosive gases shall be protected. Aluminum components are not required to be protected.
- 4.6.3 Metals shall be used in combinations that are galvanically compatible.

- A. Copper components shall not be installed directly on aluminum roofing, siding or other aluminum surfaces.
 - B. Aluminum lightning protection components shall not be installed directly on copper roofing material or other copper surfaces or below the run off of a copper surface.
 - C. Aluminum conductors and components shall not be:
 - a. Embedded in concrete or masonry.
 - b. In direct contact with a surface coated with alkaline base paint, or
 - c. Installed in wet locations, for example eave troughs or downspouts.
 - d. Installed in direct contact with earth.
 - D. Components used for connection of aluminum down conductors to copper or copper-clad grounding equipment shall provide separation between aluminum and copper materials. These fittings may be a Stainless steel sleeve with internal separation or other connector that provides proper separation of aluminum and copper components.
- 4.6.4 Unless otherwise indicated in this standard, an air terminal shall be provided for each part of a structure that is likely to be damaged by lightning. Based on the individual design requirements of the level of protection required.

5. Level 1 Air Terminal Installation Requirements

5.1 Early Streamer Emission Air Terminals

- A. ESE Air Terminals shall be mounted at a height consistent with the requirements of Section 4.2.3 or a minimum of 20' above all projections on the roof.

See Figure 5.1.1 for sample mast mounting details.

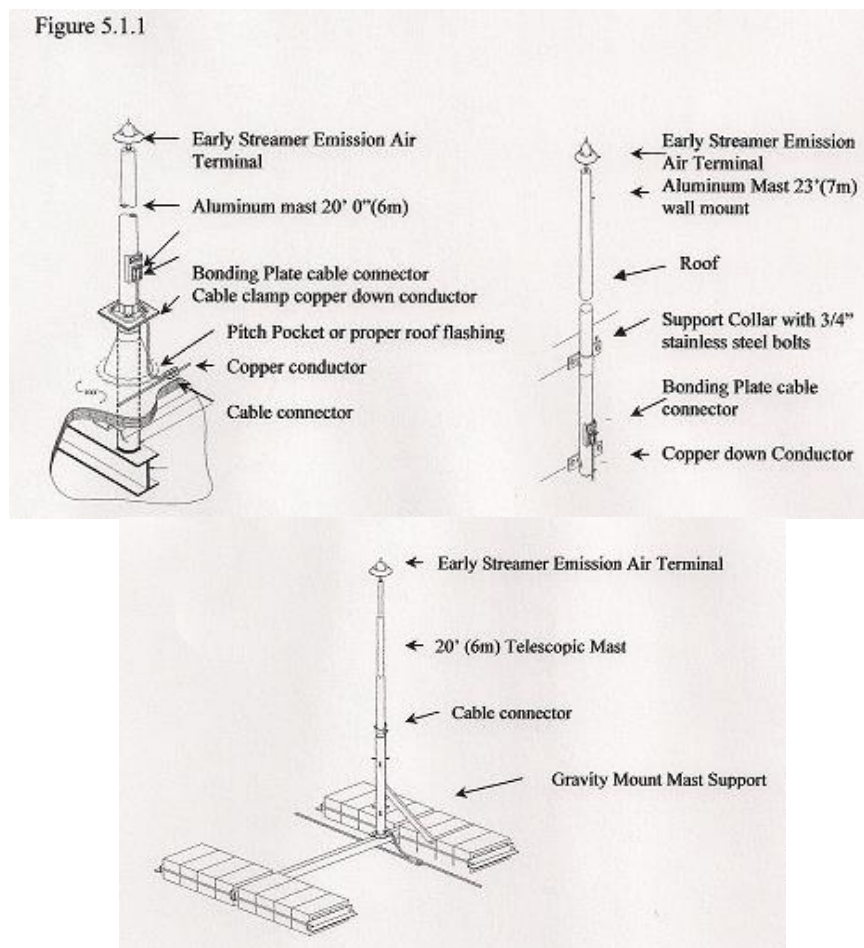

- B. ESE Air Terminals shall be provided in proper quantity and location based on the system design under Manufacturer's Standard. See Figure 3.5.1 Level 1 requirements. The recommended number and placement of air terminals is based on Heary Bros.' experience and its air terminals and the configuration of those terminals have not been scientifically proven or guaranteed to have a measurable zone of protection. Consumers should be aware that the NFPA, in issuing its standard for lightning protection, NFPA 780, states that the NFPA "does not independently test, evaluate or verify the accuracy of any information or the soundness of any judgment contained in its codes and standards."
- C. Additional ESE air terminals shall be provided in situations where steeples, cupolas, crosses, stacks, chimneys, etc. project above the protected roof area. This requirement applies to all projections which could provide a potential upward streamer release. The addition air terminals shall be provided regardless of whether or not the projection is within or outside the area covered by the system design under the Manufacturer's Standard. See Figure 5.1.2. The recommended number and placement of air terminals is based on Heary Bros.' experience and its air terminals and the configuration of those terminals have not been scientifically proven or guaranteed to have a measurable zone of protection. Consumers should be aware that the NFPA, in issuing its standard for lightning protection, NFPA 780, states that the NFPA "does not independently test, evaluate or verify the accuracy of any information or the soundness of any judgment contained in its codes and standards."

Figure 5.1.2

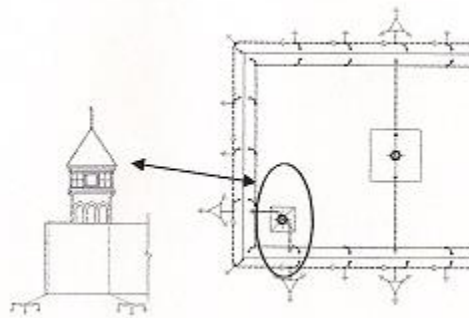

- D. Conductors shall be securely fastened to roof or structure at intervals not exceeding 3'0" on center.
- E. ESE Air Terminals shall be provided with a minimum of two paths to ground. Cables shall maintain a horizontal or downward path to ground to avoid "U" and "V" (down and up) pockets. See Figure 5.1.4
- F. No Bend of a conductor shall form an included angle of less than 90 degrees or have a radius of bend less than 8 inches nor shall a conductor rise greater than 8". However conductors may raise a rate of 3" per 12" of run. See Figure 5.1.3 and Figure 5.1.4

Figure 5.1.3

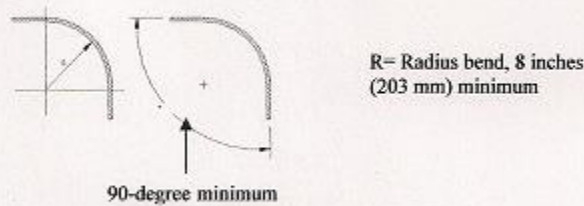

NOTE: Through roof, through wall and tee type connectors do not need to comply with this requirement

Figure 5.1.4

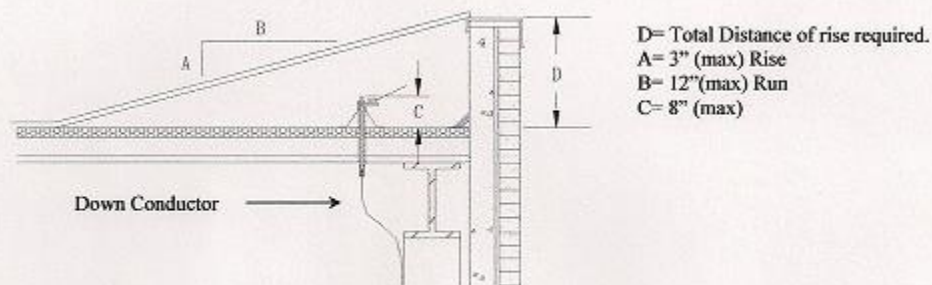

Note: Ramp may be constructed of wood, metal, fiberglass, plastic, PVC etc, provided the construction is such that it will be resistant to corrosion and rot. The conductor shall be attached or support on ramp as required in Section 5.1.D

- 5.1.1 In situations where multiple air terminals are required, the perimeter air terminals shall be positioned so that they are not more than 230' (70m) for the outside edge of the building nor shall the ESE Air Terminals be spaced more than 460' (140m) apart at any time. A cross run cable shall be provided at intervals of 200' (61m) when building exceeds 1000' (305m) in length in any direction. See Fig 5.1.1.1. The recommended number and placement of air terminals is based solely on Heary Bros.' 30 years of experience and its air terminals and the configuration of those terminals have not been scientifically proven or guaranteed to have a measurable zone of protection. Consumers should be aware that the NFPA, in issuing its standard for lightning protection, NFPA 780, states that the NFPA, "does not independently test, evaluate or verify the accuracy of any information or the soundness of any judgment contained in its codes and standards."
- 5.1.2 Down Conductors in situations where multiple ESE Air Terminals are required shall be spaced at intervals no more than 500' (152m) apart around the perimeter of the structure. The recommended number and placement of air terminals is based solely on Heary Bros.' 30 years of experience and its air terminals and the configuration of those terminals have not been scientifically proven or guaranteed to have a measurable zone of protection. Consumers should be aware that the NFPA, in issuing its standard for lightning protection, NFPA 780, states that the NFPA, "does not independently test, evaluate or verify the accuracy of any information or the soundness of any judgment contained in its codes and standards."

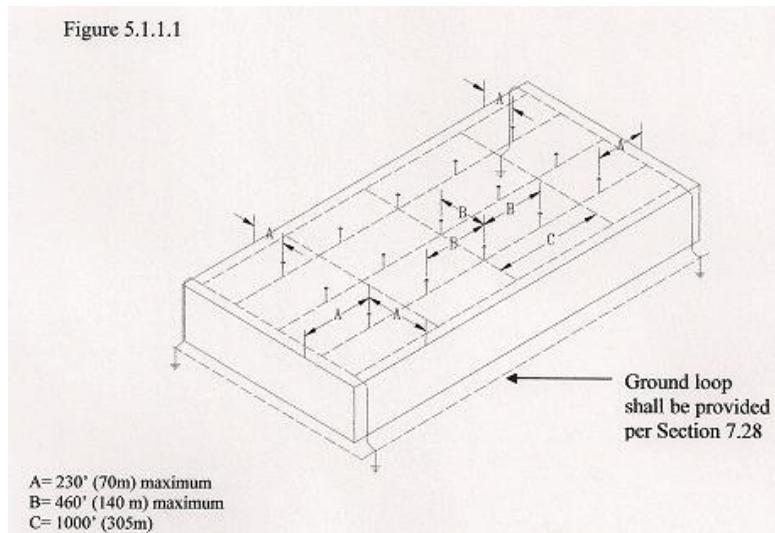

6. Level 1 Bonding Requirements

6.1 Roof top Interconnection loop

- A. An interconnection loop around the perimeter of the roof structure shall be provided to which ESE Ground Conductors shall be bonded.
- B. Loops shall be provided at all intermediate and lower roof levels and connected at a minimum of two (2) locations to the down conductors.
 - a. Bonding connections shall be made with main size conductor to all rebar, reinforcing rod, structural steel, interior wall wire mesh, nylon mesh in stucco walls, etc. whether exposed or not at all inside and outside corners of structure as a minimum. Additional bonding connections shall be made at intervals not exceeding 60' (18m) around the perimeter of the structure. Care shall be taken to assure that all rebar, reinforcing rod, structural steel, interior wall wire mesh, nylon mesh in stucco walls, et. Whether exposed or not is electrically continuous or made so. (See Fig. 6.2.4 and Fig 6.25).
 - b. Down Conductors shall be bonded to the structural steel, reinforcing rod or other structural support at the top and bottom of conductor run.

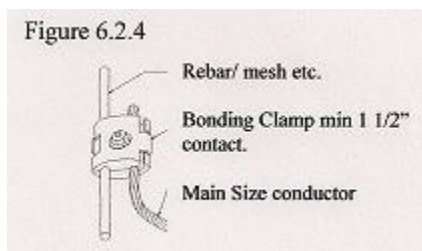

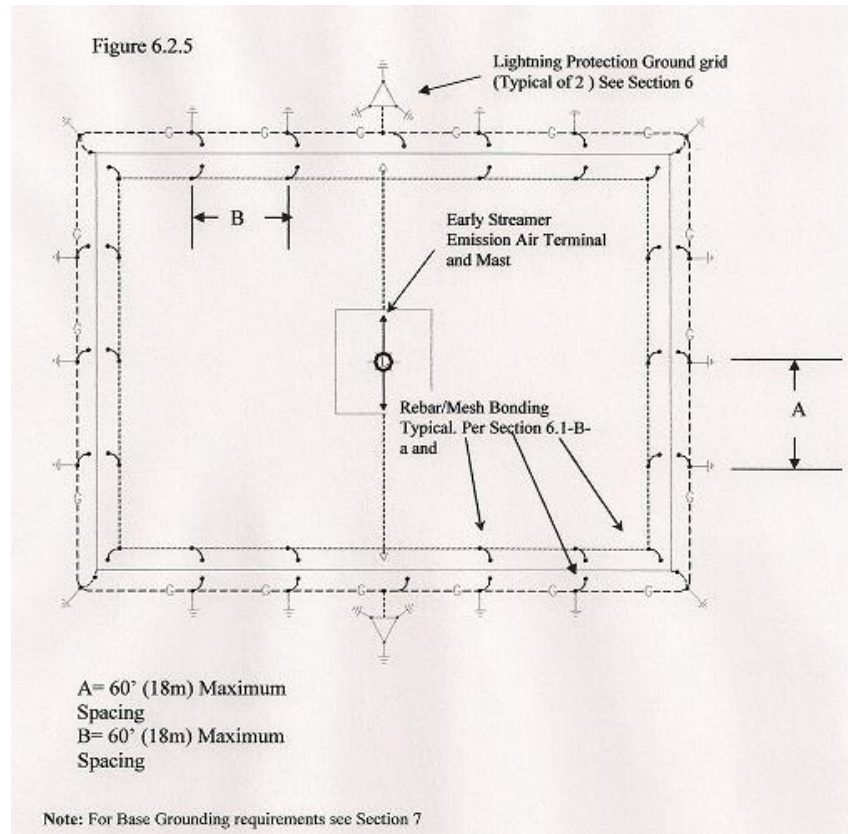

6.2 Bonding Requirements

- A. Roof top air handling units, equipment, or other roof top equipment shall be bonded to the system where the equipment is within 6' (1.8m) of a lightning protection conductor unless;
- B. Inherently bonded to the lightning protection system.
- C. Sanitary vents, roof drains, flashings, copings, etc. located within 6' (1.8m) of a lightning protection conductor, shall be bonded via secondary sized conductor to the lightning protection system.

7. Level 1 Grounding System Requirements

7.1 Down Conductors

- 7.1.1 A minimum of Two (2) Down Conductors Shall be provided for each ESE Lightning Protection System. In cases where multiple ESE Air Terminals are used then additional down conductors shall be provided in accordance with Section 5.1.2
- 7.1.2 Down Conductors shall be spaced at least 10' (3m) apart.
- 7.1.3 Down conductors and other conductor where exposed to potential mechanical damage shall be protected against such damage by means of PVC, Fiberglass conduit sleeve, or metal conduit. (Metal conduit may be used provided the upper and lower portions are bonded to the down conductor). At ground level the bottom 8' (2.4m) of exposed down conductor shall be protected. See figure 7.2.1.1

7.1.4 Down Conductors may be coursed within the construction of the building provided they are properly protected. See Figure 7.2.1.2

Figure 7.2.1.1

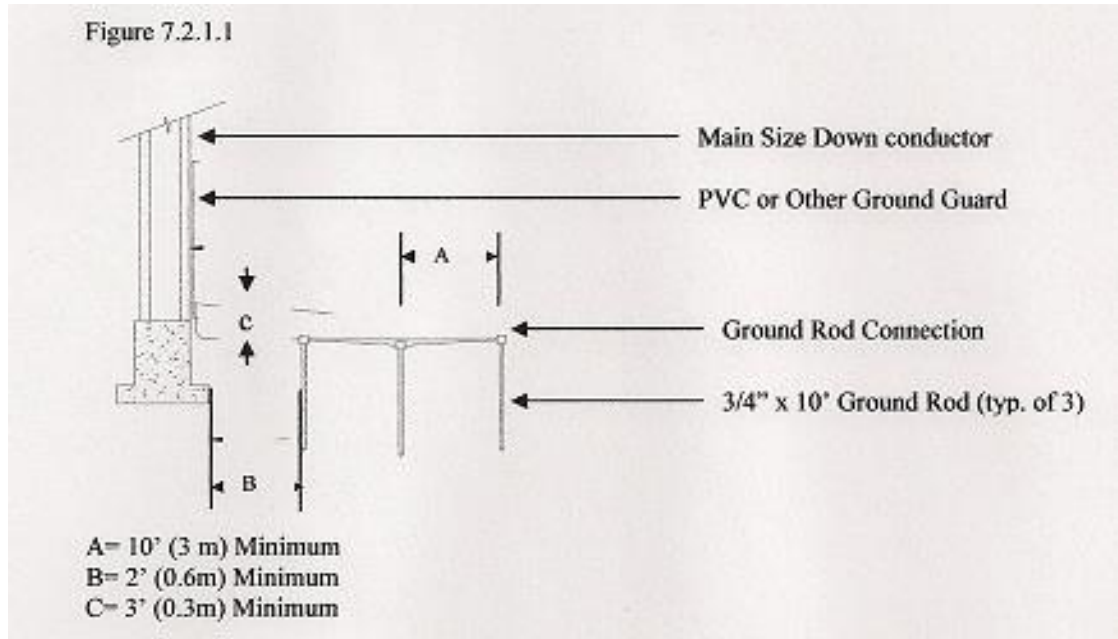
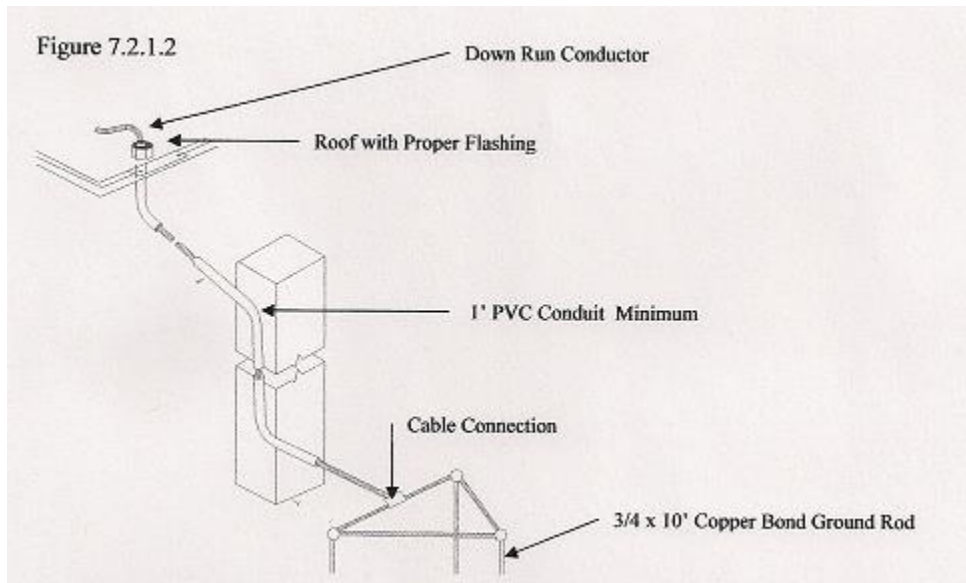

Figure 7.2.1.2



- 7.1.5 For masts that are electrically conductive then the mast shall be permitted to be used as a down conductor.
- A. If electrically continuous, structural steel shall be permitted to be used as the down conductor.
 - B. Test joints shall be provided for each down conductor. They shall be accessible and located as near as practicable to the ground termination.
- 7.1.6 Masonry Anchors used to secure the lightning protection materials shall have a minimum outside diameter of ¼ in. (6.4mm) and shall be set with care. Holes made to receive the body of the anchor shall be of correct size, made with the proper tools and made in brick, stone or other masonry unit. Fasteners shall not be installed in mortar joints. When anchors are installed, the fit shall be tight against moisture, thus reducing the possibility of damage due to freezing.
- 7.1.7 Connector Fittings shall be used at all “end to end,” “tee” or “Y” splices of lightning conductors. They shall be attached so as to withstand a pull test of 200 lbs. Fittings used for required connections shall be of bolted, welded or high compression type and bear the ARL Listing and UL Listing.
- 7.1.8 Conductors shall be fastened securely to the structure upon which they are placed at intervals not exceeding 3 ft (1m). The fasteners, attached by nails, screws, bolts or adhesives as necessary, shall not be subject to breakage and shall be of the same material as the conductor or of a material as resistant to corrosion as that of the conductor. No combination of materials shall be used that forms an electrolytic couple of such nature that, in the presence of moisture, corrosion is accelerated.
- 7.2 Grounding
- 7.2.1 Ground Terminations: A study shall be conducted to engineer a grounding system to a maximum of 10 ohms resistance in accordance with IEEE fall of potential ANSI/IEEE 141, *Recommended Practice for Electric Power Distribution for Industrial Power Plants*, method. The components for the grounding system shall be selected to be suitable for the soil conditions and the other side factors such as cathodic protection.
- 7.2.2 Ground electrodes shall be of copper-bond steel in sufficient number as to achieve a 10-ohm maximum resistance to ground. Ground electrodes shall be installed so that the top of the electrode is a minimum 3’ (1m) below finished grade minimum and 2’ (0.6m) away from the foundation wall. See Figure 7.2.1.1
- 7.2.3 Ground rod terminations. The down conductor shall be attached to the ground rod by mechanical clamp, exothermic welding or brazing. Clamps shall be suitable for direct burial.
- 7.2.4 Each down conductor shall terminate at a ground terminal system. A minimum of 3 ground terminals shall be provided per down conductor location. Configured either in a straight line or in delta formation. Where the ground terminals are spaced a minimum of 10’ (3m) apart. See Figures 7.2.3.1 and 7.2.3.2

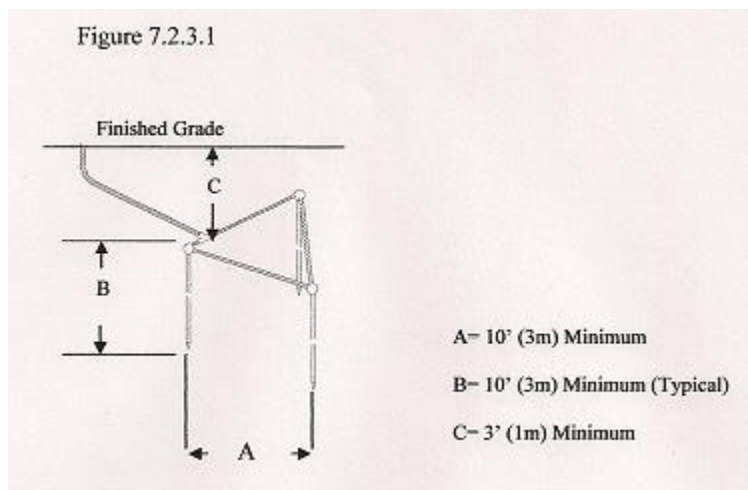
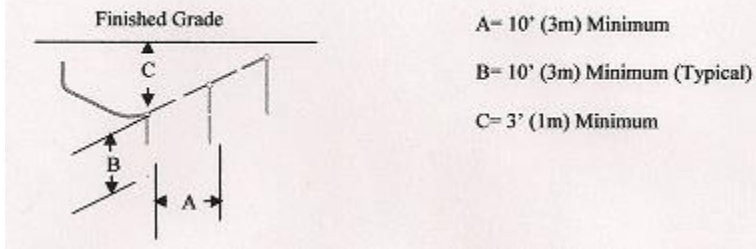
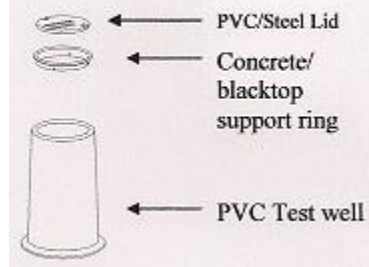

Figure 7.2.3.2



- 7.2.5 Ground terminals located under slabs or in crawl spaces shall be installed as near as practicable to the outside perimeter of the structure.
- 7.2.6 Electrical system grounding electrodes shall not be used in lieu of lightning ground rods. This provision shall not prohibit the required bonding together of grounding electrodes of different systems.
- NOTE 1:** For Further information, see NFPA 70 National Electric Code, which contains detailed information on the grounding of electrical systems.
- NOTE 2:** Ground rod or ground ring/loop electrodes should be installed below the frost line where practicable and in accordance with Section 7.2.8

Figure 7.2.6.1



- 7.2.7 Grounding ring/loop Electrode encircling the structure shall be provided and in direct contact with the earth at a depth of not less than 2ft. The ground ring conductor shall be sized at a minimum of that of the main sized conductor. See Figure 7.2.8.1

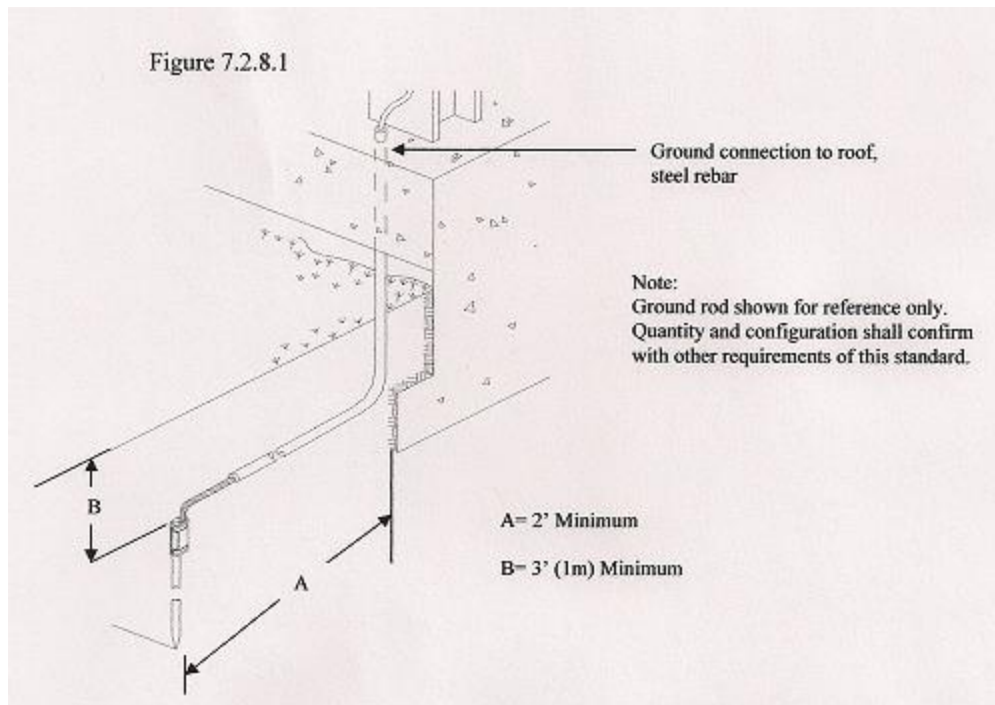

- 7.2.8 Common Grounding. All grounding media in or on a structure shall be interconnected to provide a common ground potential. This shall include, but not be limited to lightning protection, electrical services, telephone and antenna system grounds as well as underground metallic piping systems. Such piping systems include water service, well casings located within 25ft (7.6m) of the structure, underground conduits (not already bonded) etc. Main size lightning conductors shall be used for interconnecting these grounding systems to the lightning protection system.
- 7.2.9 Common Ground Bonding. If electric telephone or other systems are bonded to metallic water pipe, only one connection from the lightning protection system to the water pipe system is necessary, provided that the water pipe is electrically continuous between all systems. In situations where there are separate services for domestic and fire water entering the building both systems shall be bonded to the lightning protection grounding system. This may be accomplished via direct connection or through the ground loop system.

8. Level 1 Structural Steel Systems

- 8.1 General. The steel framework of a structure shall be permitted to be utilized as the main conductor of a lightning protection system if it is electrically continuous or is made electrically continuous.
- 8.2 Steel Structure Terminals. Ground terminals shall be connected to approximately every other steel column around the perimeter of the structure at intervals averaging not more than 60ft (18m). Ground terminals shall be connected together via a main size conductor as indicated in sec 7.2. Connections shall be made near the base of the column, with a surface contact area not less than 8 sq inches (5200mm²) or by exothermic welding. Bonding plates shall have bolt pressure cable connectors and shall be bolted securely to the structural steel framework so as to maintain electrical continuity.
- 8.3 Connections to Framework. Conductors shall be connected to cleaned areas of the structural steel framework by the bonding of plates having a surface contact area of not less than 8 sq in (5200mm²). The area of attachment shall be free of paint, grease oil and debris. (See Figure 8.3.1)

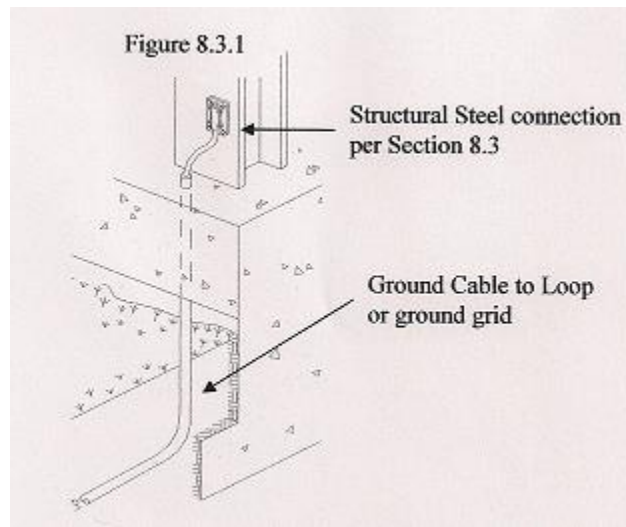

- 8.4 Early Streamer Emission Air terminals shall be permitted to be bonded directly to structural, by means of direct attachment through mast or by use of two interconnection wires routed through roof and bonded at the top of the structural steel in the manner described in Section 8.3
- 8.5 Metal Bodies. Certain Metal bodies located outside or inside the structure contribute to lightning hazards because they are grounded or assist in providing a path to ground for lightning currents. Such metal bodies shall be bonded to the lightning protection system in accordance with Section 4.5.
- 8.6 Concealment in Steel Reinforced Concrete. Conductors or other components of the lightning protection system concealed in steel reinforced concrete units shall be connected to the reinforcing steel. Concealed down conductors shall be connected to vertical reinforcing steel. Roof conductors or other concealed horizontal conductors runs shall be connected to reinforcing steel/structural steel at intervals not exceeding 60ft (18m) and at all corners. See Section 6.
- 8.7 Down Conductors coursed on or in reinforced concrete columns or on structural steel columns shall be connected to the reinforcing steel and/or structural steel member at its upper and lower extremities. In the case of long vertical members an additional connection shall be made at intervals not exceeding 200ft (60m). Such connections shall be made using listed clamps or listed bonding plates or by exothermic welding. The use of PVC conduit or other non-metallic chase does not negate the need for these interconnections.

LEVEL 2

MANUFACTURER'S INSTALLATION
STANDARD

FOR

EARLY STREAMER EMISSION
LIGHTNING PROTECTION SYSTEMS

9. Level 2 General Installations and Component Requirements

- 9.1 An ESE lightning protection system installation consists of the following interconnected parts
- One or more ESE air terminals
 - Mast and mounting systems – as required based on level of protection desired
 - Bonding conductors – as required based on level of protection.
 - Ground system – Single grid to loop conductor system
 - Equipotential Bonding
 - Transient Voltage Surge Suppression
- 9.2 The number of ESE air terminals will depend on the system design under the manufacturer’s Standard based on the area as indicated in Figure 3.5.1 for Level 2 Systems. The recommended number and placement of air terminals is based solely on Heary Bros.’ 30 years of experience and its air terminals and the configuration of those terminals have not been scientifically proven or guaranteed to have a measurable zone of protection. Consumer should be aware that the NFPA, in issuing its standard for lightning protection, NFPA 780, states that the NFPA, “does not independently test, evaluate or verify the accuracy of any information or the soundness of any judgment contained in its codes and standards.”
- 9.3 Components Tables Figure 9.3.1 and Figure 9.3.2 provide minimum sizes and weights for use in ESE lightning protection system installation.

Figure 9.3.1

Type of conductor	Minimum Diameter	Copper Standard/ Metric	Aluminum Standard/ Metric
ESE Air Terminal	1/2" / 12.7mm	1/2" / 12.7 mm	1/2" / 12.7 mm
Main Conductor Cable	Min Size each strand Weight Per Length Cross Sectional area	14AWG 375lbs /1000/ or 558 g/m 115,000 CM / 58 mm ²	13AWG 190lbs/1000/ 283 g/m 192000 CM/ 97 mm ²
Ground Terminals	Ground Rod / Ground Plate	3/4" x 10' (20mm x 3000mm) / 24" x 24" x 20 gauge (600mm x 600mm) pure Copper plate minimum of 2 contact points each 8 sq inch contact to plate	NA

Figure 9.3.2

Early Streamer Emission Air Terminal

A= 12"
B= 9"

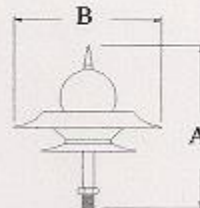

9.4 ESE Air Terminals shall be sufficiently rigid to withstand mechanical damage. They shall be constructed of copper, copper alloy, aluminum or stainless steel. The main conductive parts of the ESE air terminals shall have the minimum dimensions in accordance with Figures 9.3.1 and Figure 9.3.2 for minimum dimensions of ESE Air Terminals Installation: Air terminals and their supports shall be mounted in such a way as to withstand the lightning currents, electromotive force, corrosion and effects of weather, heat, humidity, snow and wind

NOTE: Wind design requirements should be consistent with local building code requirements.

9.4.1 Where an air terminal or mast is supported by conductive guys, the guys shall be connected from their points of anchorage to the closest down conductor(s) by a conductor equivalent in size to that of the down conductor(s).

9.4.2 The tip of any ESE air terminal shall not be less than 20' (6.1m) above the protected structures, including antennas, cooling towers, tanks, roof and masts.

9.4.3 The ESE air terminals shall be mounted on structures such as flagpole, the top of pylons, light standards or on dedicated supports for structures at certain facilities, such as, sports facilities and stadiums, golf courses, public parks, camping sites and racetracks. The ESE unit shall be mounted at an elevation as indicated in Section 9.4.2.

9.5 Storage Areas for flammable and combustible liquids or flammable gases. Structures containing these materials shall be grounded, but grounding alone does not constitute sufficient protection against atmospheric discharges.

9.5.1 Electrical Surge Suppression device shall be internally redundant and modular, in both surge suppression elements and fusing in construction for ease of field reparability. Manufacturers shall warranty the modules and fuse for the lifetime of the unit, with a minimum 10-year full unit warranty. Units shall be mounted as to minimize inductance installation. (I.e. As close to equipment to be protected or by use of documented low inductance cabling.)

Note 1: Electrical systems and utilization equipment within the structure may require further surge suppression. Such protection is not part of this standard. NFPA 70, National Electric Code and ANSI/IEEE C62.41-1991 2nd Edition, shall be consulted for further information and installation requirements.

Note 2: Illustrations shown in this are those of Heary Brothers Lightning Protection Co., Inc. (HBLP) and its division Lightning Preventor of America (LPA). HBLP and LPA do not manufacture or warranty surge protection devices. Warranties required of this standard shall be the responsibility of the surge protection device manufacturer.

9.6 General. In determining the necessity of bonding a metal body to a lightning protection system, the following factors shall be considered:

- A. Bonding is required only if there is a likely to be a side flash between the lightning protection system and other grounded medium.
- B. The influence of a non-grounded metal body, such as a metal window frame in a non-conductive medium, is limited to its effectiveness as a short circuit conductor if a side flash occurs therefore, does not necessarily require bonding to the lightning protection system.
- C. Bonding distance requirements depend on the technical evaluation of the number of down conductors and their location, the interconnection of other grounded systems, the proximity of grounded metal bodies to the down conductors and the flashover medium (air or solid materials).
 - (a) Metal bodies located in a steel frame structure shall be permitted to be inherently bonded through construction and further bonding shall not be required.
 - (b) Metal antenna masts or supports located on a protected structure shall be bonded to the lightning protection system using main size conductors and listed fittings. The height of the air terminal shall still maintain the minimum protection above these objects as specified in Section 9.4.2.

9.7 Components

- 9.7.1 A lightning protection system shall be made of components that are resistant to corrosion or shall be acceptably protected against corrosion. The following materials are acceptable:
- A. Copper of the grade required for commercial electrical work. Or a copper alloy with similar characteristics. Usually of 98 percent conductivity when annealed.
 - B. Aluminum conductors as acceptable as electrical grade aluminum.
- 9.7.2 Components shall be protected against deterioration due to local conditions. Any part of a copper system that is exposed to direct action of chimney gases or other similar corrosive gases shall be protected. Aluminum components are not required to be protected.
- 9.7.3 Metals shall be used in combinations that are galvanically compatible.
- A. Copper components shall not be installed directly on aluminum roofing, siding, or other aluminum surfaces.
 - B. Aluminum lightning protection components shall not be installed directly on copper roofing material or other copper surfaces or below the run off of a copper surface.
 - C. Aluminum Conductors and components shall not be:
 - a) Embedded in concrete or masonry;
 - b) In direct contact with a surface coated with alkaline base paint; or
 - c) Installed in wet locations, for example eave troughs or downspouts.
 - d) Installed in direct contact with earth
 - D. Components used for connection of aluminum down conductors to copper or copper-clad grounding equipment shall provide separation between aluminum and copper materials. These fittings may be a stainless steel sleeve with internal separation or other connector that provides proper separation of aluminum and copper materials.
- 9.7.4 Unless otherwise indicated in this standard, an air terminal shall be provided for each part of a structure that is likely to be damaged by lightning. Based on the individual design requirements of the level of protection required.

10. Level 2 Air Terminals Installation Requirements

10.1 Early Streamer Emission Air Terminals

- A. ESE Air Terminals shall be mounted at a height consistent with the requirements of Section 9.4.2 or a minimum of 20' above all projections on the roof. See Figure 10.1.1 for sample mast mounting details.

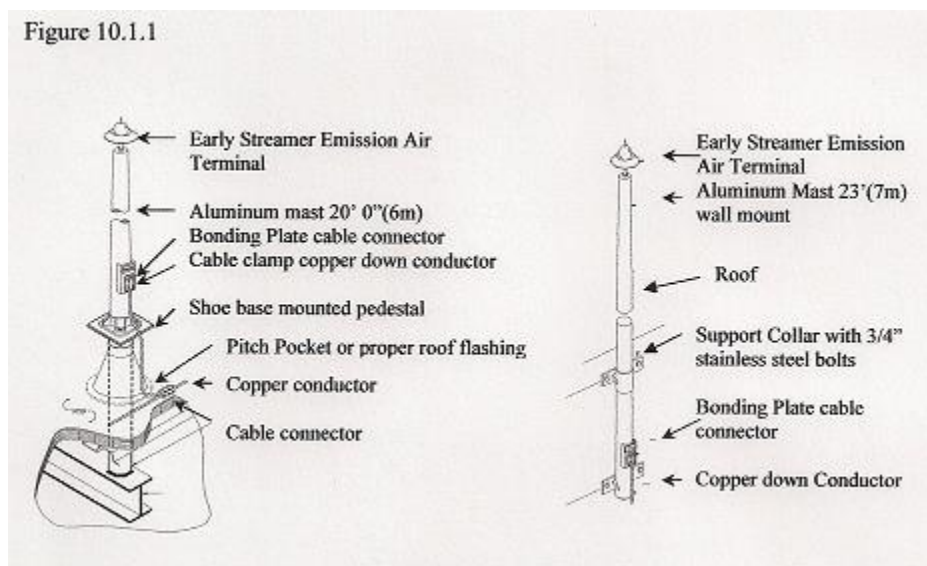

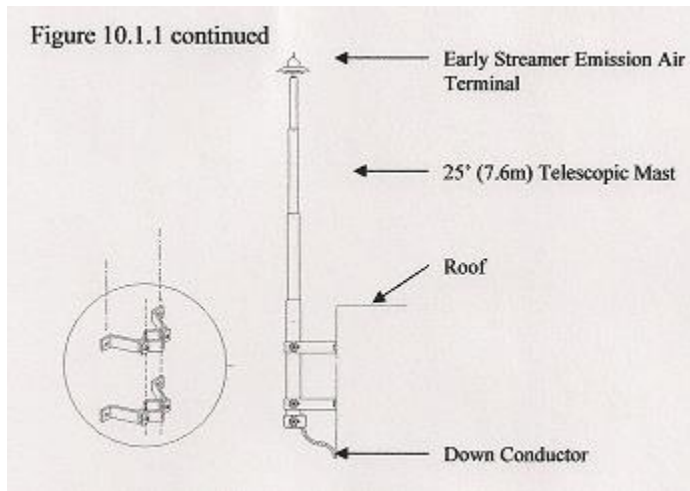
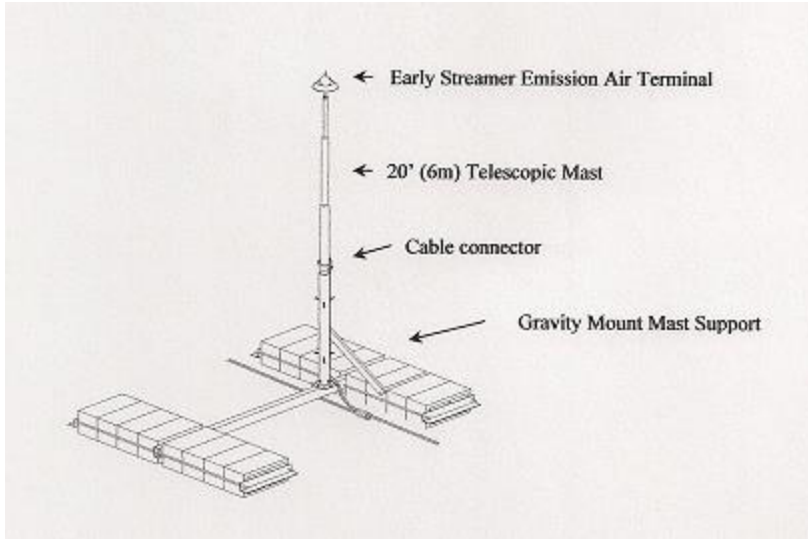

- 10.2 ESE Air Terminals shall be provided in proper quantity and location based on the system design under the Manufacturer's Standard. See Figure 3.5.1 for Level 2. The recommended number and placement of air terminals is based on Heary Bros.' experience and its air terminals and the configuration of those terminals have not been scientifically proven or guaranteed to have a measurable zone of protection. Consumers should be aware that the NFPA, in issuing its standard for lightning protection, NFPA 780, states that the NFPA "does not independently test, evaluate or verify the accuracy of any information or the soundness of any judgment contained in its codes and standards."
- 10.3 Conductors shall be securely fastened to roof or structure at intervals not exceeding 3'0" on center.
- 10.4 Additional ESE air terminals shall be provided in situations where steeples, cupolas, crosses, stacks, chimneys, etc project above a protected roof area. This requirement applies to all projections which could provide a potential upward streamer release. The addition air terminals shall be provided regardless of whether or not the projection is within or outside the area covered by the system design under the Manufacturer's Standard. See Figure 10.2.1. The recommended number and placement of air terminals is based on Heary Bros.' experience and its air terminals and the configuration of those terminals have not been scientifically proven or guaranteed to have a measurable zone of protection.

Consumers should be aware that the NFPA, in issuing its standard for lightning protection, NFPA 780, states that the NFPA “does not independently test, evaluate or verify the accuracy of any information or the soundness of any judgment contained in its codes and standards.”

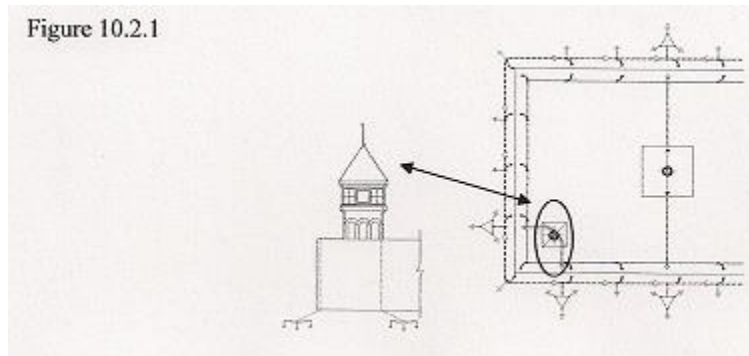

- 10.5 ESE Air Terminals shall be provided with a minimum of two paths to ground. Cables shall maintain a horizontal or downward path to ground to avoid “U” and “V” (down and up) pockets.
- 10.6 No Bend of a conductor shall form an included angle of less than 90 degrees or have a radius of bend less than 8 inches nor shall a conductor rise greater than 8”. However Conductors may rise at a rate of 3” per 12” of run. See Figure 10.5.1 and Figure 10.6.1

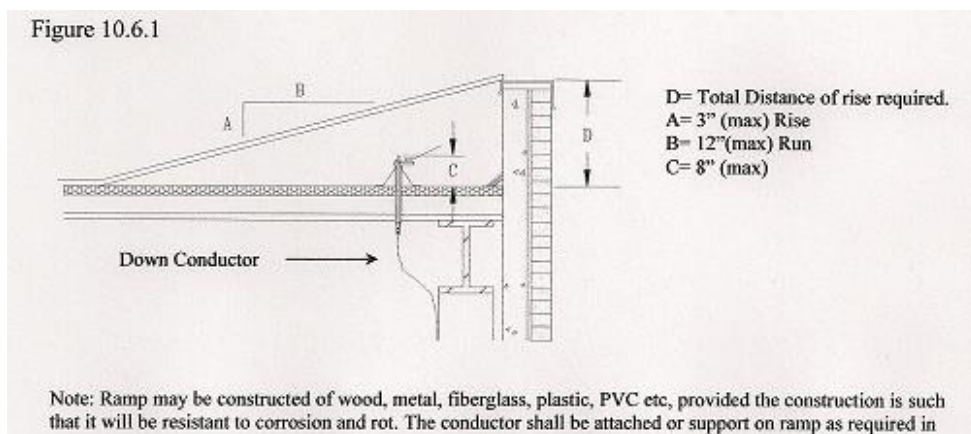
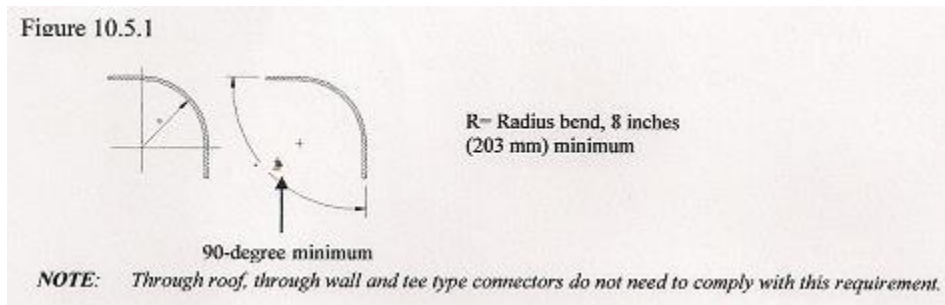

- 10.7 In situations where multiple air terminals are required, the perimeter air terminals shall be positioned so that they are no more than 230’ (70m) from the outside edge of the building nor shall be ESE Air

Terminals be spaced more than 460' (140m) apart at any time. A cross run cable shall be provided at intervals of 200' (61m) When building exceed 1000' (305m) in length in any direction. See Figure 10.8.1. The recommended number and placement of air terminals is based solely on Heary Bros.' 30 years of experience and its air terminals and the configuration of those terminals have not been scientifically proven or guaranteed to have a measurable zone of protection. Consumers should be aware that the NFPA, in issuing its standard for lightning protection, NFPA 780, states that the NFPA, "does not independently test, evaluate or verify the accuracy of any information or the soundness of any judgment contained in its codes and standards."

- 10.8 Down Conductors in situations where multiple ESE Air Terminals are required shall be spaced at intervals no more than 500' (152m) apart around the perimeter of the structure.

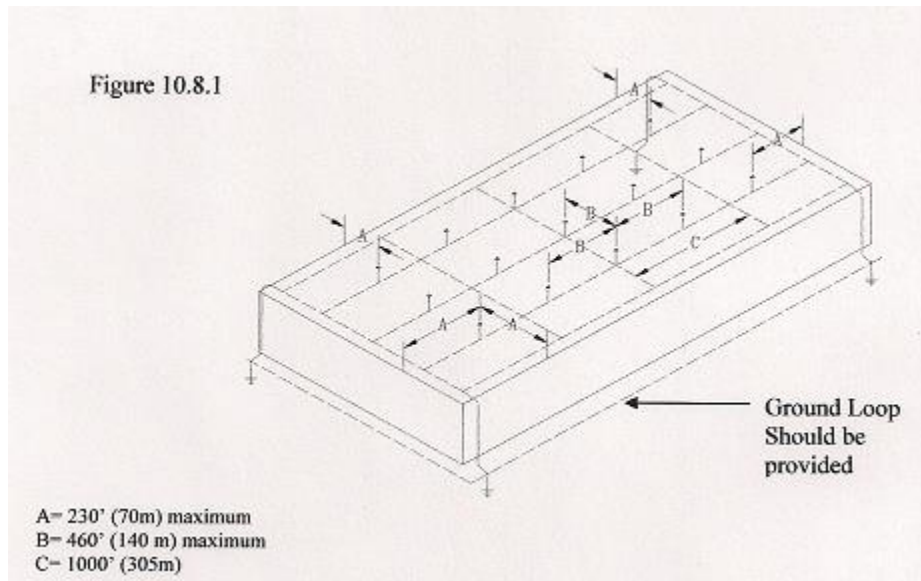

- 10.9 Bonding connections shall be made with main size conductor to all rebar, reinforcing rod, structural steel, interior wall wire mesh, nylon mesh in stucco walls, etc., whether exposed or not, at the upper and lower extremities of each down conductor. Care shall be taken to assure that all rebar, reinforcing rod, structural steel, interior wall mesh, nylon mesh in stucco walls etc, whether exposed or not is electrically continuous or made so. (See Fig. 10.9.1 and Fig 10.9.2).

Figure 10.9.1

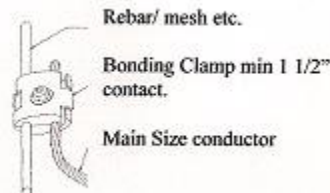
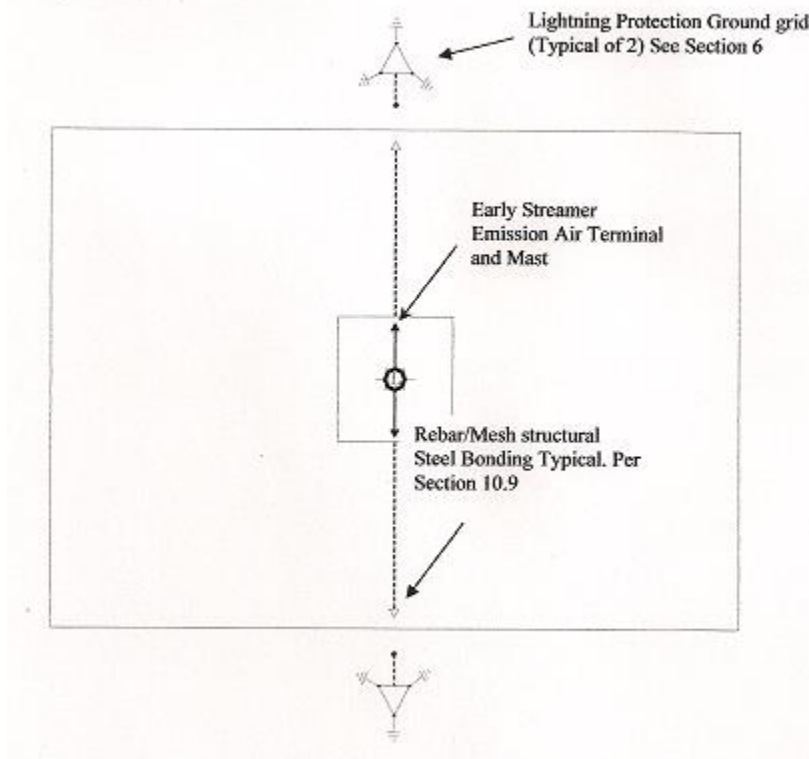

Figure 10.9.2



11. Level 2 Bonding Requirements

11.1 Roof top air handling units, equipment, or other roof top equipment shall be bonded to the system where the equipment is within 6' (1.8m) of a lightning protection conductor unless.

A. Inherently bonded to the lightning protection system.

11.2 Sanitary vents, roof drains, flashings, copings, etc located within 6' (1.8m) of a lightning protection conductor, shall be bonded via secondary sized conductor to the lightning protection system.

12. Level 2 Grounding System Requirements

12.1 Down Conductors and Grounding

12.2 A minimum of two (1) down conductors shall be provided for each ESE Lightning Protection System. In cases where multiple ESE Air Terminals are used then additional down conductors shall be provided in accordance with Section 10.8.

12.3 A single down conductor shall be permitted to be used where the length of run does not exceed 65ft (19m).

12.4 If the horizontal length is greater than the vertical length, two (2) down conductors shall be required and separated a minimum of 10' (3m).

12.4.1 For lengths greater than 65' (19m) two conductors shall be required.

12.4.2 For masts, a single down conductor only shall be required.

12.4.3 If electrically conductive, the mast shall be permitted to be used as the down conductor.

12.5 Down Conductors and other conductor where exposed to potential mechanical damage shall be protected against such damage by means of PVC, Fiberglass conduit sleeve, or metal conduit. (Metal conduit may be used provided the upper and lower portions are bonded to the down conductor). At ground level the bottom 8' (2.4m) of exposed down conductor shall be protected. See figure 12.4.1.

- 12.6 Down Conductors may be coursed within the construction of the building provided they are properly protected. See Figure 12.4.2.

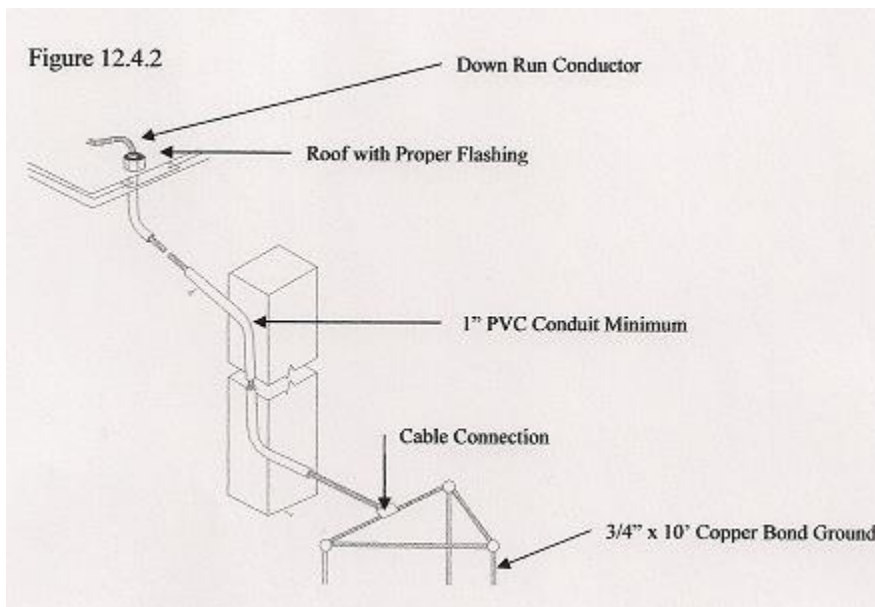
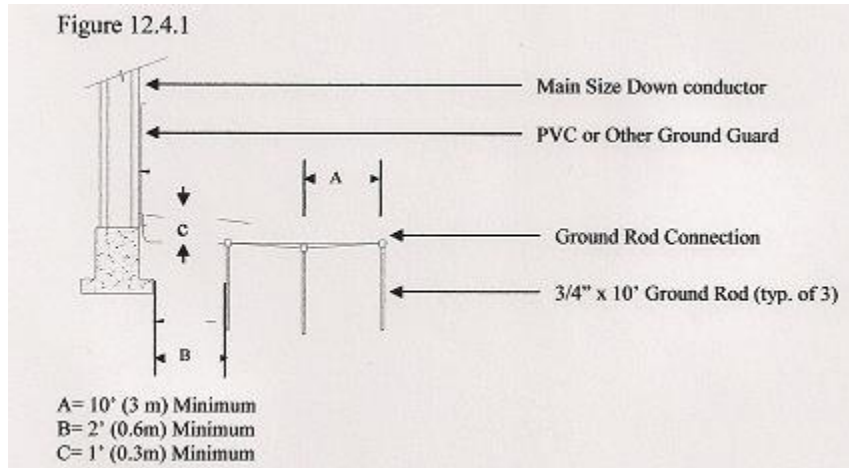

- 12.7 For masts that are electrically conductive then the mast shall be permitted to be used as a down conductor.
- 12.7.1 If electrically continuous, structural steel shall be permitted to be used as the down conductor.
- 12.8 Masonry Anchors used to secure the lightning protection components shall have a minimum outside diameter of 1/4" (6.4mm) and shall be set with care. Holes made to receive the body of the anchor shall be of correct size, made with the proper tools and made in brick, stone or other masonry unit. Fasteners shall not be installed in mortar joints. When anchors are installed the fit shall be tight against moisture, thus reducing the possibility of damage due to freezing.
- 12.9 Connector Fittings shall be used at all "end to end", "tee" or "y" splices of lightning conductors. They shall be attached so as to withstand a pull test of 200 lbs. Fittings used for required connections shall be of bolted, welded, or high compression type and bear the ARL Listing and UL Listing.
- 12.10 Conductors shall be fastened securely to the structure upon which they are placed at intervals not exceeding 3 ft (1m). The fasteners, attached by nails, screws, bolts or adhesives as necessary, shall not be subject to breakage and shall be of the same material as the conductor or of a material as resistant to

- corrosion as that of the conductor. No combination of materials shall be used that forms an electrolytic couple of such nature that, in the presence of moisture, corrosion is accelerated.
- 12.11 Ground Terminations: A study shall be conducted to engineer a grounding system to a maximum of 10 ohms resistance in accordance with IEEE fall of potential ANSI/IEEE 141, *Recommended Practice for Electric Power Distribution for Industrial Power Plants*, method. The components for the grounding system shall be selected to be suitable for the soil conditions and the other site factors such as cathodic protection.
- 12.12 Ground electrodes shall be of copper-bond steel in sufficient number as to achieve a 10-ohm maximum resistance to ground. Ground electrodes shall be installed so that the top of the electrode is a minimum 1' (0.3m) below finished grade minimum and 2' (0.6m) away from the foundation wall. See Figure 12.4.1
- 12.13 Ground Rod terminations. The down conductor shall be attached to the ground rod by mechanical clamp, exothermic welding or brazing. Clamps shall be suitable for direct burial.
- 12.14 Each down conductor shall terminate at a ground terminal system. A minimum of 3 ground terminals shall be provided per down conductor location. Configured either in a straight line or in delta formation. Where the ground terminals are spaced a minimum of 10' (3m) apart. See Figures 12.4.1 and 12.4.2.
- 12.15 Ground terminals located under slabs or in crawl spaces shall be installed as near as practicable to the outside perimeter of the structure.
- 12.16 Electrical system grounding electrodes shall not be used in lieu of lightning ground rods. This provision shall not prohibit the required bonding together of grounding electrodes of different systems.

NOTE 1: For further information, see NFPA 70 National Electric Code, which contains detailed information on the grounding of electrical systems.

- 12.17 Ground ring/loop electrode encircling the structure should be provided and in direct contact with the earth at a depth of not less than 2 ft. The ground ring conductor shall be sized at a minimum of that of the main sized conductor.
- 12.18 Common Grounding. All grounding media in or on a structure shall be interconnected to provide a common ground potential. This shall include lightning protection, electric service, telephone and antenna system grounds as well as underground metallic piping systems. Such piping systems include water service, well casings located within 25ft (7.6m) of the structure, underground conduits (not already bonded) etc. Main size lightning conductors shall be used for interconnecting these grounding systems to the lightning protection system.
- 12.19 Common Ground Bonding. If electric, telephone or other systems are bonded to metallic water pipe; only on connection from the lightning protection system to the water pipe system is necessary, provided that the water pipe is electrically continuous between all systems. In situations where there are separate services for domestic and fire water entering the building both systems shall be bonded to the lightning protection grounding system. This may be accomplished via direct connection or through the ground loop system.
- 12.20 If the horizontal length is greater than the vertical length, two down conductors shall be required and separated a minimum of 10' (3m).
- (a) For lengths greater than 65' (19m) two conductors shall be required.
- (b) For masts, a single down conductor only shall be required.
- (c) If electrically conductive, the mast shall be permitted to be used as the down conductor.

13. Level 2 Structural Steel Systems

- 13.1 General. The steel framework of a structure shall be permitted to be utilized as the main conductor of a lightning protection system if it is electrically continuous or is made electrically continuous.

- 13.2 Steel Structure Terminals. Ground terminals shall be connected to approximately every other steel column around the perimeter of the structure at intervals averaging not more than 60 ft (18m). Connections shall be made near the base of the column, with a surface contact area not less than 8 sq inches (5200mm²) or by exothermic welding. Bonding plates shall have bolt pressure cable connectors and shall be bolted securely to the structural steel framework so as to maintain electrical continuity.
- 13.3 Connections to Framework. Conductors shall be connected to cleaned areas of the structural steel framework by the bonding of plates having a surface contact area of not less than 8 sq inches (5200mm²). The area of attachment shall be free of paint, grease oil and debris.
- 13.4 Early Streamer Emission Air Terminals shall be permitted to be bonded directly to structural, by means of direct attachment through mast or by use of two interconnection wires routed through roof and bonded at the top of the structural steel in the manner described in Section 13.3.
- 13.5 Metal Bodies. Certain metal bodies located outside or inside the structure contribute to lightning hazards because they are grounded or assist in providing a path to ground for lightning currents. Such metal bodies shall be bonded to the lightning protection system in accordance with Section 11.
- 13.6 Concealment in Steel Reinforced Concrete. Conductors or other components of the lightning protection system concealed in steel reinforced concrete units shall be connected to the reinforcing steel. Concealed down conductors shall be connected to vertical reinforcing steel. Roof conductors or other concealed horizontal conductor runs shall be connected to reinforcing steel and structural steel at intervals not exceeding 60ft (18m) and at all corners. See Section 10.9.
- 13.7 Down Conductors coursed on or in reinforced concrete columns or on structural steel columns shall be connected to the reinforcing steel and/or structural steel member at its upper and lower extremities. In the case of long vertical members an additional connection shall be made at intervals not exceeding 200 ft (60m). Such connections shall be made using listed clamps or listed bonding plates or by exothermic welding. The use of PVC conduit or other non-metallic chase does not negate the need for the interconnections.

LEVEL 3

**MANUFACTURER'S INSTALLATION
STANDARD**

FOR

**EARLY STREAMER EMISSION
LIGHTNING PROTECTION SYSTEMS**

- 14.1 An ESE lightning protection system installation consists of the following interconnected parts see figure 14.1.1.
- a. One or more ESE air terminals.
 - b. Mast and mounting systems – as required based on level of protection.
 - c. Ground system – Single grid to loop conductor system.
 - d. Equipotential Bonding.
 - e. Transient Voltage Surge Suppression.

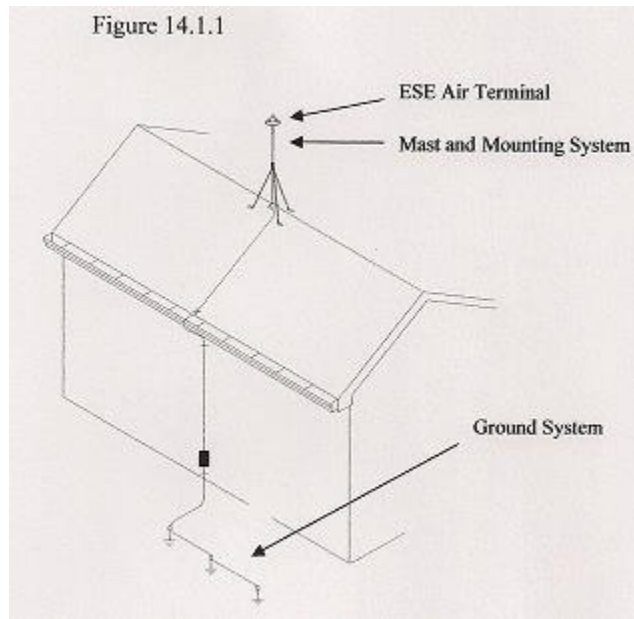

- 14.2 The number of ESE air terminals will depend on the system design under the Manufacturer's Standard based on the area as indicated in Figure 3.5.1 for Level 3 Systems. The recommended number and placement of air terminals is based solely on Heary Bros.' 30 years of experience and its air terminals and the configuration of those terminals have not been scientifically proven or guaranteed to have a measurable zone of protection. Consumers should be aware that the NFPA, in issuing its standard for lightning protection, NFPA 780, states that the NFPA, "does not independently test, evaluate or verify the accuracy of any information or the soundness of any judgment contained in its codes and standards."
- 14.3 Components Tables Figure 14.3.1 and Figure 14.3.2 provide minimum sizes and weights for use in ESE lightning protection system installation.

Figure 14.3.1

Type of conductor	Minimum Diameter	Copper Standard/ Metric	Aluminum Standard/ Metric
ESE Air Terminal	1/2" / 12.7mm	1/2" / 12.7 mm	1/2" / 12.7 mm
Main Conductor Cable	Min Size each strand Weight Per Length Cross Sectional area	16AWG 190lbs /1000/ or 278 g/m 61900 CM / 35 mm ²	14AWG 110lbs/1000/ 164 g/m 98600 CM/ 50 mm ²
Ground Terminals	Ground Rod / Ground Plate	5/8" x 8' (16 mm x 2400mm) / 18" x 18" x 20 gauge (460mm x 460mm) pure Copper plate minimum of 2 contact points each 8 sq inch contact to plate	NA

Figure 14.3.2

Early Streamer Emission Air Terminal

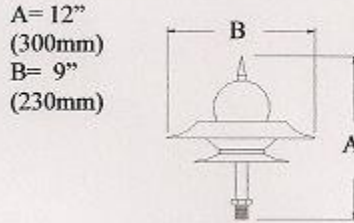

- 14.4 ESE Air Terminals shall be sufficiently rigid to withstand mechanical damage. They shall be constructed of aluminum, copper, copper alloy, or stainless steel. The main conductive parts of the ESE air terminal shall have the minimum dimensions in accordance with Figures 14.3.1 and Figure 14.3.2.
- 14.5 ESE Air Terminals Installation: Air terminals and their supports shall be mounted in such a way as to withstand the lightning currents, electromotive force, corrosion and effects of weather, heat, humidity, snow and wind.
 - 14.5.1 Where an air terminals or mast is supported by conductive guys, the guys shall be connected from their points of anchorage to the closest down conductor(s) by a conductor equivalent in size to that of the down conductor(s).
 - 14.5.2 The tip of any ESE air terminal shall not be less than 7' (2.1m) above the protected structures, including antennas, cooling towers, tanks, roof and masts.
 - 14.5.3 The ESE air terminals shall be mounted on structures such as flagpole, the top of pylons, light standards or on dedicated supports for structures at certain facilities, such as sports facilities and stadium, golf courses, public parks, camping sites and racetracks. The ESE unit shall still be mounted at an elevation as indicated in Section 14.5.2
 - 14.5.4 Storage areas for flammable and combustible liquids or flammable gases. Structures containing these materials shall be grounded, but grounding alone does not constitute sufficient protection against atmospheric discharges.
 - 14.5.5 Electrical Surge Suppression devices shall be internally redundant and modular, in both surge suppression elements and fusing in construction for ease of field reparability. Manufacturers shall warranty the modules and fuse for the lifetime of the unit, with a minimum 10-year full unit warranty.

Units shall be mounted as to minimize inductance installation. (I.e. As close to equipment to be protected or by use of documented low inductance cabling).

NOTE 1: Electrical systems and utilization equipment within the structure may require further surge suppression. Such protection is not part of this standard. NFPA 70, National Electric Code and ANSI/IEEE C62.41-1991 2nd Edition, shall consulted for further information and installation requirements.

NOTE 2: Illustrations shown in this standard are those of Heary Brothers Lightning Protection Co., Inc. (HBLP) and its division Lightning Preventor of America (LPA). HBLP and LPA do not manufacture or warranty surge protection devices. Warranties required of this standard shall be the responsibility of the surge protection device manufacturer.

- 14.6 General. In determining the necessity of bonding a metal body to a lightning protection system, the following factors shall be considered:
- A. Bonding is required only if there is a likely to be a side flash between the lightning protection system and other grounding medium.
 - B. The influence of a non-grounded metal body, such as metal window frame in a non-conductive medium, is limited to its effectiveness as a short circuit conductor if a side flash occurs therefore, does not necessarily require bonding to the lightning protection system.
 - C. Bonding distance requirements depend on the technical evaluation of the number of down conductors and their location, the interconnection of other grounded systems, the proximity of grounded metal bodies to the down conductors and the flashover medium, (Air or solid materials).
 - D. Metal bodies located in a steel frame structure shall be permitted to be inherently bonded through construction and further bonding shall not be required.
 - E. Metal antenna masts or supports located on a protected structure shall be bonded to the lightning protection system using main size conductors and listed fittings. The height of the air terminal shall still maintain the minimum projection above these objects as specified in section 14.5.2 and the object shall be bonded to the lightning protection system by means of main sized conductor.

15. Level 3 Components

- 15.1 A lightning protection system shall be made of components that are resistant to corrosion or shall be acceptably protected against corrosion. The following materials are acceptable:
- A. Copper of the grade required for commercial electrical work. Or a copper alloy with similar characteristics. Usually of 98 percent conductivity when annealed.
 - B. Aluminum conductors as acceptable as electrical grade aluminum.
- 15.1.1 Components shall be protected against deterioration due to local conditions. Any part of a copper system that is exposed to direct action of chimney gases or other similar corrosive gases shall be protected. Aluminum components are not required to be protected.
- 15.2 Metals shall be used in combinations that are galvanically compatible.
- A. Copper components shall not be installed directly on aluminum roofing, siding, or other aluminum.
 - B. Aluminum lightning protection components shall not be installed directly on copper roofing material or other copper surfaces or below the run off of a copper surface.
 - C. Aluminum conductors and components shall not be embedded in concrete or masonry;
 - a) In direct contact with a surface coated with alkaline base paint; or installed in wet locations, for example eave troughs or downspouts.
 - b) Installed in direct contact with earth.
 - c) Components used for connection of aluminum down conductors to copper or copper-bond grounding equipment shall provide separation between aluminum and copper materials. These fitting may be a stainless steel sleeve with internal separation or other connector that provides proper separation of aluminum and copper materials.

- 15.2.1 Unless otherwise indicated in this standard, an air terminals shall be provided for each part of a structure that is likely to be damaged by lightning. Based on the individual design requirements of the level of protection required.

16. Level 3 Air Terminal Installation Requirements

16.1 Early Streamer Emission Air Terminals

- 16.1.1 ESE Air Terminals shall be mounted at a height consistent with the requirements of Section 14.5.2 or a minimum of 7' (2.1m) above all projections on the roof. See Figure 16.1.1 for sample mast mounting details and figure 16.1.2 for installation diagram.

Figure 16.1.1

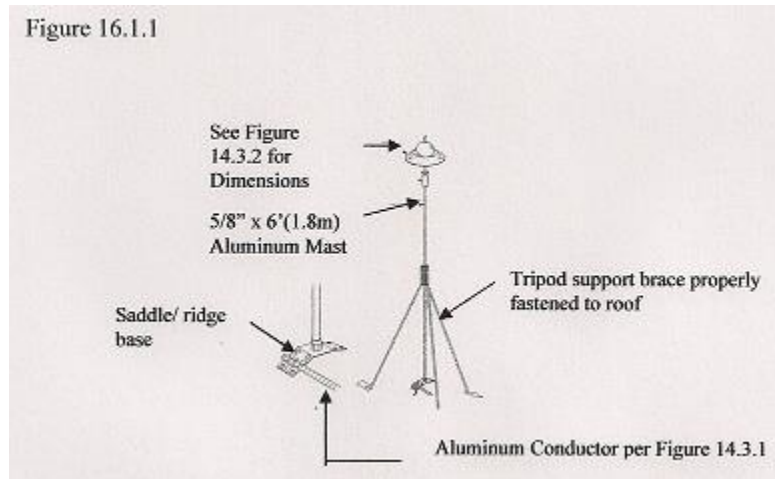
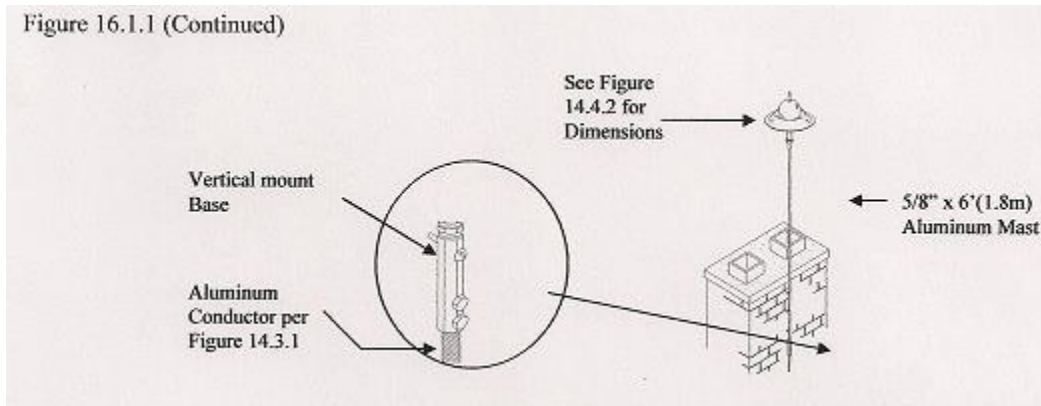
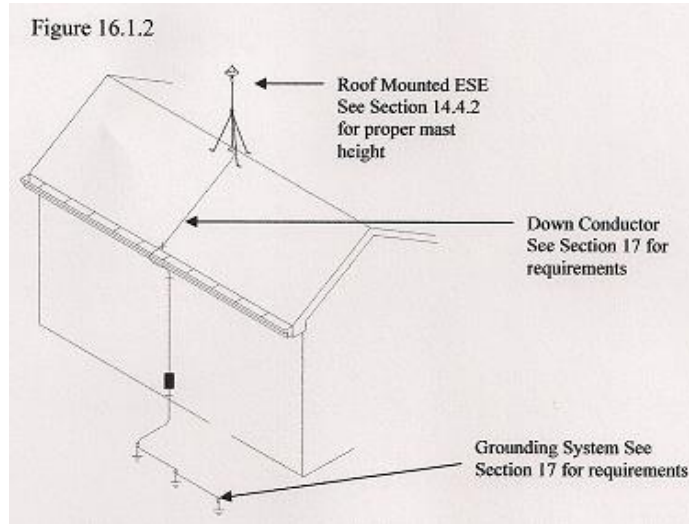
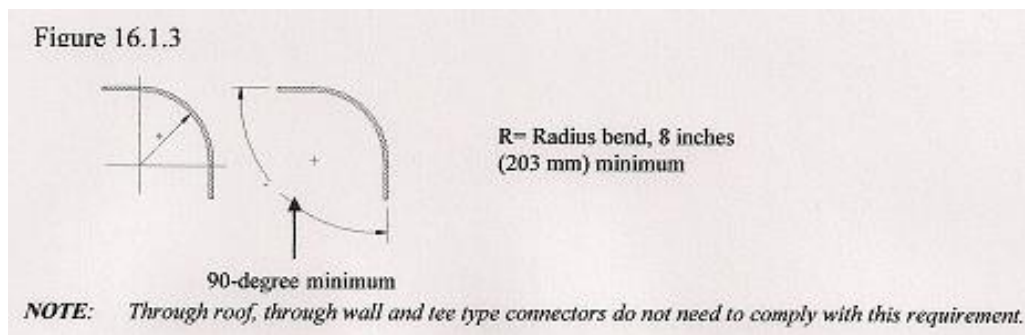

Figure 16.1.1 (Continued)





- 16.1.2 ESE Air Terminals shall be provided in proper quantity and location based on the system design under the Manufacturer's Standard. See Figure 3.5.1 and for Level 3 Systems. The recommended number and placement of air terminals is based on Heary Bros.' experience and its air terminals and the configuration of those terminals have not been scientifically proven or guaranteed to have a measurable zone of protection. Consumers should be aware that the NFPA, in issuing its standard for lightning protection, NFPA 780, states that the NFPA "does not independently test, evaluate or verify the accuracy of any information or the soundness of any judgment contained in its codes and standards."
- 16.1.3 Conductors shall be securely fastened to roof or structure at intervals not exceeding 3' (1m) on center.
- 16.1.4 The ESE Air Terminals shall be provided with a minimum of one path to ground. (See Section 17 for additional requirements) Cables shall maintain a horizontal or downward path to ground to avoid "U" and "V" (down and up) pockets. See Figure 16.1.4
- 16.1.5 No bend of a conductor shall form an included angle of less than 90 degrees or have a radius of bend less than 8 inches nor shall a conductor rise greater than 8". However Conductors may raise a rate of 3" per 12" of run. See Figure 16.1.3 and Figure 16.1.4



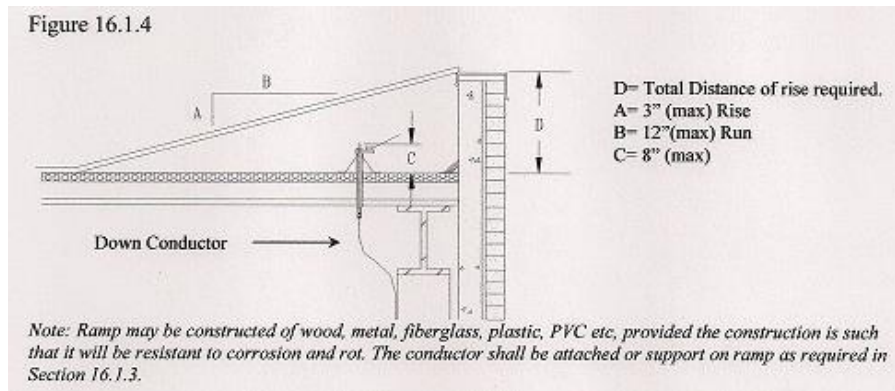

- 16.1.6 In situations where multiple air terminals are required, air terminals shall be positioned so that they are no more than 150' (45m) from the outside edge of the building nor shall they be more than 300' (90m) apart. The recommended number and placement of air terminals is based on Heary Bros.' experience and its air terminals and the configuration of those terminals have not been scientifically proven or guaranteed to have a measurable zone of protection. Consumers should be aware that the NFPA, in issuing its standard for lightning protection, NFPA 780, states that the NFPA "does not independently test, evaluate or verify the accuracy of any information or the soundness of any judgment contained in its codes and standards."
- 16.1.7 Down Conductors in situations where multiple ESE Air Terminals are required shall be installed in accordance with Section 17.
- 16.1.8 Bonding connections shall be made to all rebar, reinforcing rod, structural steel etc. at the upper on lower extremities of the down conductor. See Figure 16.18.

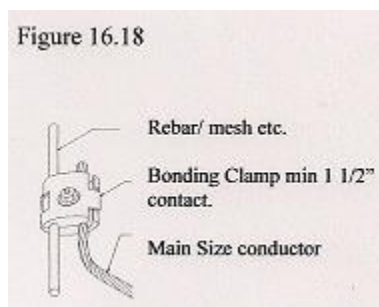

- 16.2 Roof Top Bonding Requirements;
 - 16.2.1 Roof top air handling units, equipment, or other roof top equipment shall be bonded to the system where the equipment is within 6' (1.8m) of a lightning protection conductor unless the equipment is inherently connected to the ground system through direct bond or common bond.
 - 16.2.2 Sanitary vents, roof drains, flashings, gutters, copings etc. Located within 6' (1.8m) of the lightning protection system, shall be bonded via a secondary sized conductor to the system unless the equipment is inherently bonded to the lightning protection system.

17. Level 3 Grounding System Requirements

- 17.1 A minimum of two (2) down conductors shall be provided for each ESE Lightning Protection System. In cases where multiple ESE Air Terminals are used then additional down conductors shall be provided in accordance with Section 16.1.7.
- 17.2 A single down conductor shall be permitted to be used where the length of run does not exceed 65ft (19m).

- 17.3 If the horizontal length is greater than the vertical length, two down conductors shall be required and separated a minimum of 10' (3m).
- 17.4 For lengths greater than 65' (19m) two conductors shall be required.
- 17.5 For masts, a single down conductor only shall be required.
- 17.6 If electrically conductive, the mast shall be permitted to be used as the down conductor.
- 17.7 Down Conductors and other conductor where exposed to potential mechanical damage shall be protected against such damage by means of PVC, fiberglass conduit sleeve, or metal conduit. (Metal conduit may be used provided the upper and lower portions are bonded to the down conductor). At ground level the bottom 8' (2.4m) of exposed down conductor shall be protected. See Figure 17.8.1
- 17.8 Down Conductors may be coursed within the construction of the building provided they are properly protected. See Figure 17.8.3.

Figure 17.8.1

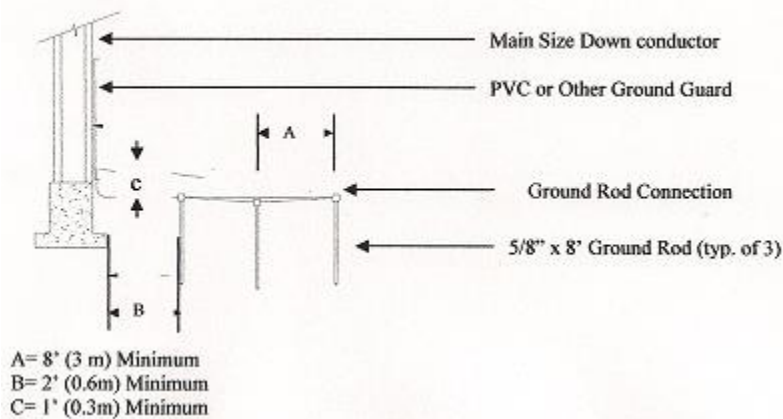
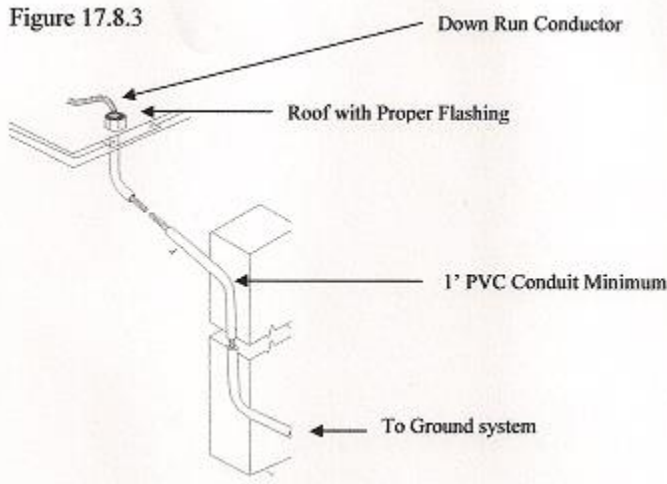

Figure 17.8.3



- 17.9 For masts that are electrically conductive then the mast shall be permitted to be used as a down conductor.
- 17.10 If electrically continuous, structural steel shall be permitted to be used as the down conductor.

- 17.11 Masonry Anchors used to secure the lightning protection components shall have a minimum outside diameter of ¼ in. (6.4mm) and shall be set with care. Holes made to receive the body of the anchor shall be of correct size, made with the proper tools and made in brick, stone or other masonry unit. Fasteners shall not be installed in mortar joints. When anchors are installed, the fit shall be tight against moisture, thus reducing the possibility of damage due to freezing.
- 17.12 Connector Fittings shall be used at all “end to end”, “tee”, or “y” splices of lightning conductors. They shall be attached so as to withstand a pull test of 200 lb. Fittings used for required connections shall be of bolted, welded or high compression type and bear the ARL Listing and UL Listing.
- 17.13 Conductors shall be fastened securely to the structure upon which they are placed at intervals not exceeding 3 ft (1m). The fasteners, attached by nails, screws, bolts or adhesives as necessary, shall not be subject to breakage and shall be of the same material as the conductor or of a material as resistant to corrosion as that of the conductor. No combination of components shall be used that forms an electrolytic couple of such nature that in the presence of moisture, corrosion is accelerated.
- 17.14 Ground Terminations: A study shall be conducted to engineer a grounding system to a maximum of 25 ohms resistance in accordance with IEEE fall of potential ANSI/IEEE 141, *Recommended Practice for Electric Power Distribution for Industrial Power Plants*, method. The components for the grounding system shall be selected to be suitable for the soil conditions and the other site factors such as cathodic protection.
- 17.15 Ground electrodes shall be of copper-bond steel or copper plate in sufficient number as to achieve a 25 ohm maximum resistance to ground. Ground electrodes shall be installed so that the top of the electrode is a minimum 1’ (0.3m) below finished grade minimum and 2’ (0.6m) away from the foundation wall. See Figure 17.8.1.
- 17.16 Ground Rod Terminations. The down conductor shall be attached to the ground rod by mechanical clamp, exothermic welding or brazing. Clamps shall be suitable for direct burial.
- 17.17 Each down conductor shall terminate at a ground terminal system. A minimum of 3 ground terminals shall be provided per down conductor location. Configures in a straight line. Where the ground terminals are spaced a minimum of 8’ (3m) apart. See Figure 17.8.1.
- 17.18 Ground terminals located under slabs or in crawl spaces shall be installed as near as practicable to the outside perimeter of the structure.
- 17.19 Electrical system grounding electrodes shall not be used in lieu of lightning ground rods. This provision shall not prohibit the required bonding together of grounding electrodes of different systems. *NOTE 1: For further information, see NFPA 70 National Electric Code, which contains detailed information on the grounding of electrical systems.*
- 17.20 Common Grounding. All grounding media in or on a structure shall be interconnected to provide a common ground potential. This shall include lightning protection, electric service, telephone and antenna system grounds as well as underground metallic piping systems. Such piping systems include water service, well casings located within 25 ft (7.6m) of the structure, underground conduits (not already bonded) etc. Main size lightning conductors shall be used for interconnecting these grounding systems to the lightning protection system.
- 17.21 Common Ground Bonding. If electric, telephone or other systems are bonded to metallic water pipe; only one connection from the lightning protection system to the water pipe system is necessary, provided that the water pipe is electrically continuous between all systems. In situations where there are separate services for domestic and fire water entering the building both systems shall be bonded to the lightning protection grounding system. This may be accomplished via direct connection or through the ground loop system.

18. Level 3 Structural Steel Systems

- 18.1 General. The steel framework of a structure shall be permitted to be utilized as the main conductor of a lightning protection system if it is electrically continuous or is made electrically continuous.
- 18.2 Steel Structure Terminals. Ground terminals shall be connected to approximately every other steel column around the perimeter of the structure at intervals averaging not more than 60ft (18m). Connections shall be made near the base of the column, with a surface contact area not less than 8 sq inches (5200mm²) or by exothermic welding. Bonding plates shall have bolt pressure cable connectors and shall be bolted securely to the structural steel framework so as to maintain electrical continuity.
- 18.3 Connections to Framework. Conductors shall be connected to cleaned areas of the structural steel framework by the bonding of plates having a surface contact area of not less than 8 sq inches (5200mm²). The area of attachment shall be free of paint, grease, oil, and debris.
- 18.4 Early Streamer Emission Air Terminals shall be permitted to be bonded directly to structural, by means of direct attachment through mast or by use of two interconnection wires routed through roof and bonded at the top of the structural steel in the manner described in Section 18.3.